

# THRU WITH RISER CONNECTIONS

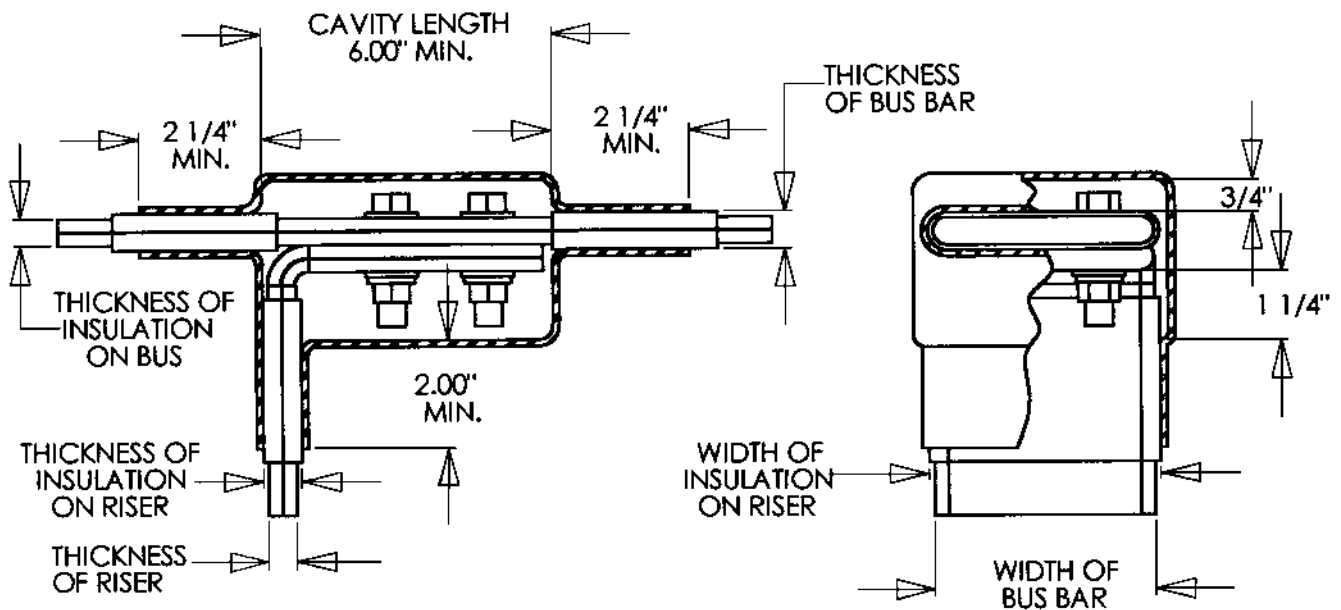

ILLUSTRATION OF CONFIGURATION #1

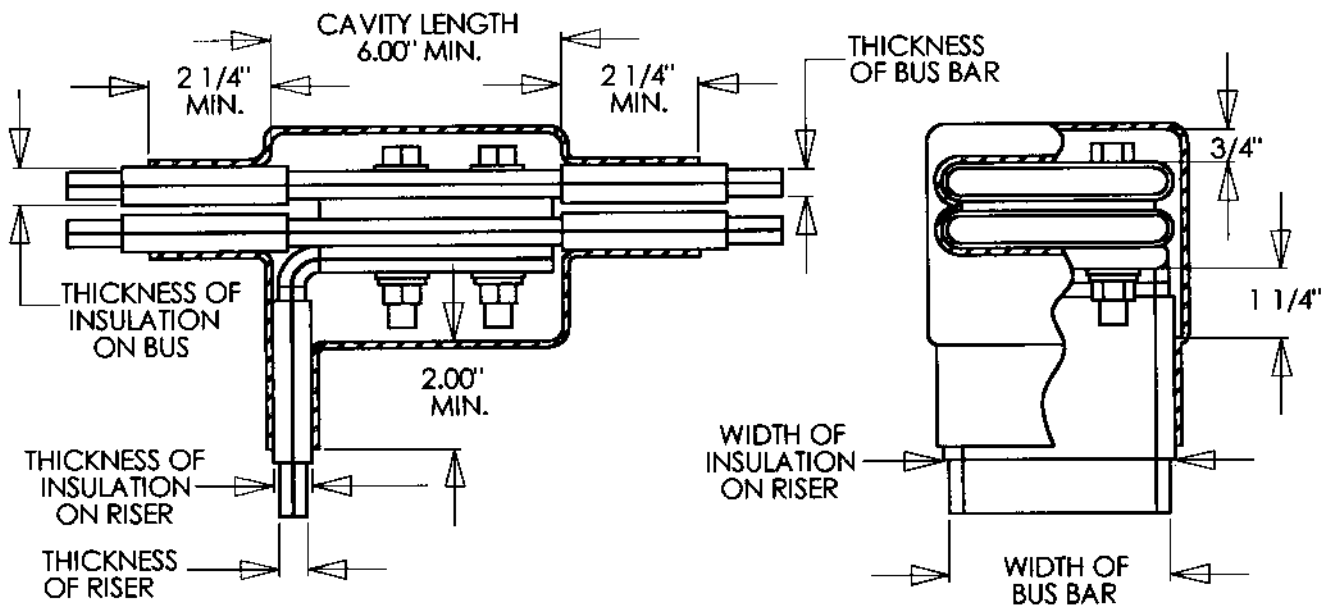

ILLUSTRATION OF CONFIGURATION #2

Variations of the above are available.  
Cable taps may be added to any configuration.

It's easy: just print, fill in and fax to  
215-766-2222.

**FAST FAX**

# INSULBOOT® THRU WITH RISER CONNECTIONS

**Standard Range** – Our standard range of Thru with Riser connections exceed 64 different configurations. Main Bus size and Riser size range from 1/4" by 2" to 3/4" by 8".

**Free Design Services** – E-mail or fax your Bus layout and we will design and supply drawings of the InsulBoot to suit your needs, usually within 2-3 days. E-mail [sales@insulboot.com](mailto:sales@insulboot.com) or fax 215-766-2222.

**Custom InsulBoot** – If it is not possible to meet your specifications from our range of standards, we will design and mold a custom InsulBoot to suit your applications, usually within 7 days.

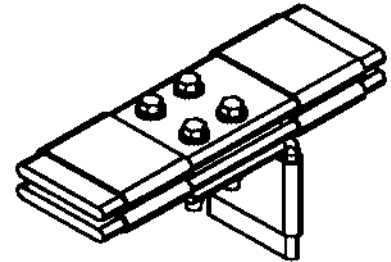
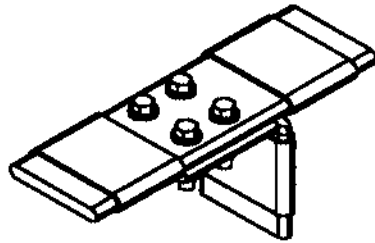

CONNECTOR TYPE  
CHECK ONE:

1

2

Provide Bus Size:  x   
THICKNESS WIDTH

If PT Tap is required, please mark position and size in sketch area provided.

Provide Tap/  
Riser Size:  x   
THICKNESS WIDTH

Bus Insulation   
THICKNESS

KV Rating

Use this area for additional notes, details or sketch of your own custom needs:

**InsulBoot Only:**

Insulboot Part #

Delivery Time

Price

Name: \_\_\_\_\_ Company: \_\_\_\_\_

Fax: \_\_\_\_\_ Phone: \_\_\_\_\_ E-Mail: \_\_\_\_\_

Quantity: \_\_\_\_\_ Requested Delivery: \_\_\_\_\_

In Stock

Custom



**InsulBoot®**  
Don't tape it, InsulBoot it!™